

Adolescents: Their Relationship to the Night and Senses in Connection with Their Own Development

by

Peter Glasby
Mt. Barker, Australia

This is a description of the workshop *Today's Child, Tomorrow's World* which took place over three days at the Kolisko Conference in Sydney, Australia, July 3–8, 2004. The methodology of the workshop was to develop several strands simultaneously, by providing experiences which were then allowed to ripen overnight and developed further on the subsequent day.

In his many courses to teachers, Rudolf Steiner gave material which, if worked with, provides a rich resource for understanding the theme, posing new questions and providing practical insight into working with adolescents in the classroom. Some of the answers are astounding. For example, education is not all about providing 'light' for the students but also 'darkness.' The beginning of the learning process is a 'conclusion,' not the end of the learning process. (Guttenhöfer, 2004). There is a need to differentiate between 'living concepts' and 'dead concepts,' a critical differentiation for education. There are implications for the way a teacher arranges his lessons and for the way in which the day is organized for the students.

In this workshop we attempted to explore this area using text material from Steiner's work, experiments, biographies, group discussion and active participation. We attempted to work with the same elements with which we work at school, i.e., the sleep life, the structure of the lesson and the day-day and three-day rhythms.

Day One

To which rhythm of life does sleep belong? The following table is a summary of the rhythms which happen within our daily lives.

Year rhythm	1 year	Physical Body	Zodiac
Month	1 month	Life Body	Moon
Week	1 week	Astral Body	Planets
Day	1 day	Ego	Sun

The astral body is the name for that spiritual member of the human being, which, in a certain way, contains our thoughts, feelings and impulses.

The day rhythm of the sun is one of renewal, of starting again. The change from our waking consciousness to sleep consciousness and then back again to waking consciousness is one of the fundamental rhythms of our existence. Without one side of the rhythm we would become ill and wasted, without the other we would lack the basis of experience for burgeoning independence. On behalf of the adolescent, who is undergoing significant changes in his or her own relation to his/her soul life, there are particular things to which the teacher should pay attention:

How is this change happening for boys and girls?

How is the 'sense life' to be cultivated?

How is the process of 'knowing' managed in school so that the students can be active participants?

In the first lecture of the series given to the first teachers at the first Waldorf school, we find the interesting statement: "*We must teach the children how to sleep.*" Surely school should be about keeping children awake, even amused, but what on earth are we to understand about teaching them to sleep? This statement leads us into the question of what is sleep? What is this state where we lose our memory, where we recover, reorder and are healed?

Our senses, which during our waking consciousness are filled with the images of the world, are closed during sleep and our consciousness is partially extinguished. Steiner described what occurs then in our soul. Freed from the distraction of the senses, the soul is given over to a world of order and archetypes out of which the creative forces of the universe flow.

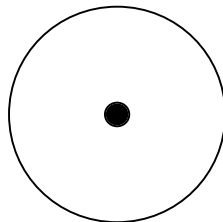

The symbol for the sun is a circle with a point in the middle. This is a picture of the human experience of the day rhythm. We are a point when we wake up into our senses, our day waking consciousness. At night we lose our consciousness into the world of sleep, the world of the dark, the stars and the periphery. What are the phenomena we can recognize in relation to our sleep life? It replenishes us so that we are ready to look at things afresh, to take up new tasks. We can

go to bed plagued by a problem and then wake to find the solution has dawned upon us. There is also a ripening that happens with sleep, where skills and abilities mature to new levels. The closeness of events from the day appears in a new perspective, which is why we often sleep on a situation before we make a decision. We can consciously take a problem or situation involving another human being into our sleep and experience how, upon waking, much of the tightness of the ‘problem knot’ has relaxed and new possibilities have emerged.



Fig. 1 – The Zodiacal human being is a recurring theme in medieval manuscripts. The signs are associated with corresponding principles in the body to show the human being, the most perfect creature in the world, as the microcosmic image of the heavens—a reflection of the celestial mirror. (from MS. Les Très Riches)

Teaching the children to sleep is also mentioned in Lecture 1 of *The Study of Man*. One could think of this as teaching the children to breathe between the periphery and the center. The medieval mystic Angelus Silesius refers to this aspect of the human existence between center and periphery:

I don't know what I am, I am not what I know,
a thing and not a thing, a drop and a circling.

This concept was depicted in medieval times many different ways; one of the most beautiful is represented in Fig.1 of Steiner's *Occult Science* (1925) in the chapter about sleep and death. Waking and sleeping are described as the astral/ego being within and without the physical/life bodies. The life body is form-giving but only if it receives from the astral body the ‘pattern forms’ or

archetypes. In wakefulness, we turn our senses to the surrounding world to form mental images. These are the ‘disturbers of the peace.’

The physical/life bodies contain the organs by which the astral body perceives the external world and has to be separated from its own world. (See *Occult Science*, p. 316) In sleep the astral body is united with the world out of which the human being is born. Apparently people in medieval times experienced this world out of which we are formed as being the zodiacal starry world.

Through the senses our experience is dismembered among twelve fields of experience. In cognition this dismemberment can be remembered, reintegrated. How this happens is important for the art of teaching. It swings between the dismemberment of waking consciousness in the twelve fields of experience (twelve senses) and the reunification in the nightly starry world of twelve zodiacal directions of space. We can have experience of the dismemberment, but we cannot so easily have experience of the reunification within the starry world. We can however, experience the extraordinary rejuvenating power of sleep.

Up to puberty the astral body is in gestation. Like the physical body in gestation, it is there, being nourished, but not yet been born until adolescence dawns. The birth of the astral body is related to the development of judgment at many levels through the high school years. This synchronization is important for educators to realize. Goethe (1960) wrote about the space between the experience of a phenomenon and the judgment about it:

One cannot give enough importance to the fact not to draw conclusions, not to prove things too quickly, or support a theory. Between the observation of the facts and the judgment, there belongs a space in time to take up the facts in a pure way. They must live. The mind has the tendency to jump to conclusions.

– Goethe, “The Experiment as the Mediator between Object and Subject”

This has important implications for the way experiences are prepared for the students, the timing of the explanation, and the way of the explanation. This principle was a central theme in the practice and art of teaching by Steiner, in lectures of 1919 and 1921. In Lecture 9 of *The Study of Man*, he characterizes the sequence: Conclusion, Judgment and Concept, whereby the Conclusion is characterized as a ‘happened event’ and stands at the beginning of the process of cognition not as a ‘conclusion concept.’

At this point in the workshop, we did two experiments (from von Mackensen, 1992). The first involved going out into the parking area and looking into a grey trough, full of water, with two tiles at each end, one vertical, one horizontal, with alternating black and white stripes painted on them. We tried to pay particular attention to the transition areas of dark to light.

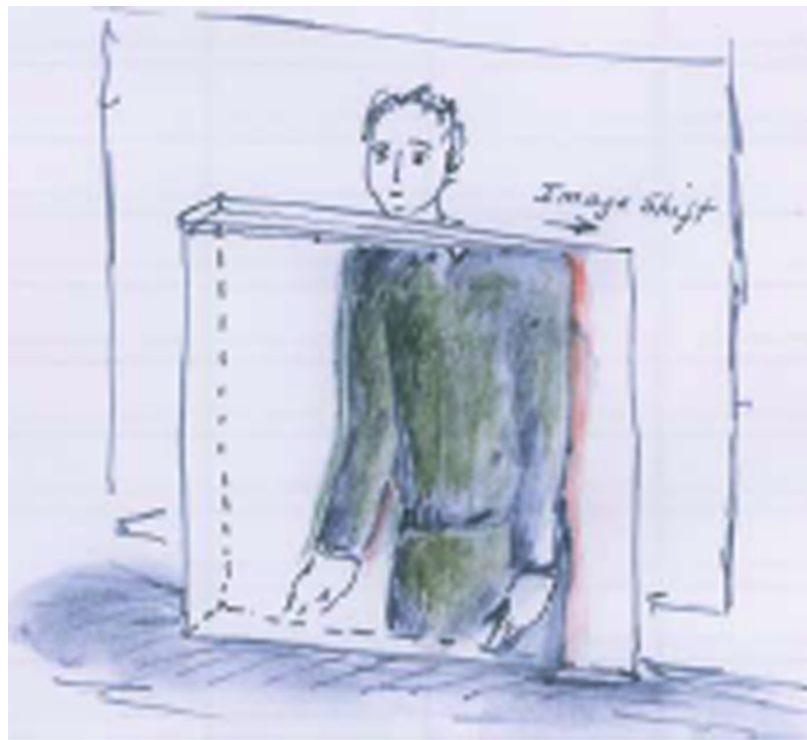

The second experiment was conducted inside. We looked at a person through a large water prism, again paying attention to the transition areas between the light and the dark.

In the first experiment we noticed, after some time, that there was a shift of the image in the water. The closer we brought our point of view to the water, the more the tile seemed to be compressed towards the surface of the water. At the same time colors appeared at the edge of the stripe—warm colors on some edges and cool colors on other edges.

What we saw through the prism has been drawn in the picture above. Notice the colors on the edge of the dark and light areas. These experiences were described and somewhat characterized, and then left. To conclude our first day the following story was told (Davidson, 1965).

In the 1860s an Irish couple, Alice and Thomas Sullivan, escaped the famine in Ireland and settled in a little farming community in the eastern United States. Their first child, a little girl, Annie, was born on April 14, 1866. Her first two years were blessed and then her life became filled with hardship. When she was two years old, her eyes became itchy and her parents, using the poor man's doctor, Time, waited for the condition to go away, but it did not and was finally diagnosed as trachoma. Soon after, her mother, Alice developed tuberculosis and the next child, Jimmy, born in 1869, had tuberculosis of the hipbone. Thomas began to drink. A third child was born. Annie became a difficult child with frequent, violent temper tantrums. One day her father said to her after she

had thrown his shaving gear all over the bathroom: “Are you a devil? See what you’ve done. Brought bad luck to the house. Seven years of bad luck.”

When Alice died, the children were all separated amongst the relatives. No one wanted Annie because of her tantrums and because by now she could hardly see. After an unsuccessful stay with a cousin, Annie and Jimmy were taken to the Tewkesbury poorhouse. Jimmy was only allowed to stay with his sister by wearing an apron. They lived in appalling conditions; their playroom was the room where those who died were kept until burial.

Then Jimmy died, and Annie’s only friends were two old women, one of whom was blind and the other arthritic. The blind woman told her stories and the arthritic woman would read to Annie from magazines in exchange for little chores. A year later, a visiting priest, Father Barbara, noticed Annie and took her away to the Sisters of Charity Hospital in Lowell, Massachusetts, for an eye operation. This was unsuccessful and Annie was returned to Tewkesbury where she continued to live in deplorable conditions for three more years, 1878–1880. During a government inspection of the poorhouse in 1880, Annie ran amongst the inspectors as they were about to depart and cried out that she wanted to go to school.

A few days later, a coach arrived to take Annie to Perkins Institution, a school for the blind and deaf. She was now fourteen years old and had had virtually no schooling. She was difficult with the other children who called her Big Annie. She learned both signing and Braille quickly but could see no point to spelling. Her stubbornness and the unkindness of one of the teachers led to another serious tantrum and her leaving the room—and nearly the school. One of the teachers, Miss Moore, took on the responsibility for Annie, setting aside time every week, during which the two studied or talked or walked the grounds. Over time Annie began to heal. She began to imitate Miss Moore’s soft voice, her gentle ways, and her kindly interest in other people. Slowly the manners she imitated became part of her, and the other girls began to warm to the new Annie. It was the beginning of a new experience, one she had not had for so long that she had forgotten it, the feeling of happiness.

Two other people contributed to Annie’s further development. One was a young Irish man whose rooms Annie cleaned. He convinced her to see a Dr. Bradford who eventually convinced Annie to attempt a series of operations, which finally gave her back relatively good vision. Annie was one of the earliest patients to have ether as an anesthetic. The second was Mrs. Hopkins, a widow from Cape Cod, who had lost a daughter of Annie’s age and who became Annie’s housemother. In fact she became a mother figure for her until she completed her education in 1886. There were eight graduates in that class and Annie led them all. She was the class valedictorian and at graduation gave a speech memorable for its universality:

“Now we are going into the busy world to take our share of life’s burdens and do our little to make the world better, wiser and happier. . . . Self-development is a benefit, not only to the individual but also to humanity. Every person who improves herself is aiding the progress of society, and everyone who stands still is holding it back.”

Annie was dreading what life would now bring her after graduation. As she contemplated an uncertain future, the principal of the school brought her a letter which asked if she would consider taking a position as governess for a little blind, deaf, mute girl from southern United States. The girl’s name was Helen Keller.

Day Two

The question arose about scientific language and the appropriateness of its use. This led to the consideration of ‘dead concepts’ and ‘living concepts.’ Scientific language can carry implicitly dead concepts within it. Sometimes these unconsciously-carried concepts are brought to consciousness with application and then they may shock us. This type of experience is becoming more common as the applications of biotechnology become more prevalent in society.

On the one hand it is necessary that children learn names of things and have knowledge about the actual nature of the world—how high mountains are, how deep the sea is, how long rivers are, what time it takes to travel between places. In learning about rocks and volcanoes in class six, one may well learn some of the language of geology such as igneous rocks, plutonic rocks, sedimentary rocks and so forth. No real model is implied—the names are descriptive.

An example of inappropriate language is the language of rays and particles in explanations of brightness and shadow in classes 6, 7 and 8. In the light ray example a model is implied. There, it is better to develop your own language as in the cases of Von Mackensen (1992) and Maier (1986).

We read a section from Chapter 8 of *The Study of Man* (Steiner, 1919) about the senses and the polarity of disparateness in the day waking state compared to the unity of the night state. This gave us indications about working with the night and the process of judgment. The integration of sensory experience is an important part of process of judgment, and Steiner described how it begins in the way that sensory experience is integrated, as in the example of looking at a shape with color. There the sense of sight and the sense of movement are integrated. The senses give us a separate experience of existence; in fact many separate experiences, which, Steiner suggested, have twelve sensory fields. This disparity of the twelve senses and the unity of the archetypal human being represented by the twelve zodiacal signs forms an interesting polarity.

Night 'I'

Unity of the twelve zodiacal signs as representing the archetypal Human being

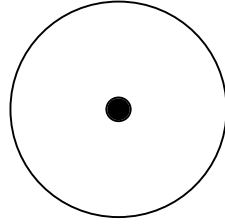

Day 'I'

Disparity of the twelve senses

We tried integrating the two experiences from yesterday, the experiment in which we looked at the striped tiles in water and the experiment in which we looked through the prism. In summarizing the experiences we made the following list:

- Colors appeared on the edges of the light and dark.
- Different colors appeared. On one edge there were warm colors, on the other there were cool colors.
- There was a shift in the image under water. The closer the eye was to the trough water surface, the greater the shift and the more intensive the color.

The connection of these phenomena was not yet clear so we performed a new experiment to help relate the different experiences above (von Mackensen, 1992).

A glass tank was filled with water and placed high up for all to see, in front of a white board. Dettol or Savlon was added to the water and clouds of turbidity formed. These took on a warm reddish color. Next a black board was placed behind the tank and another over the top of the tank. Now the clouds of turbidity took on a cooler, bluish hue.

In the second experiment I filled the second prism with water and started by putting my face up close and then backing away from the prism. My view to the audience was like this. When I was close to the prisms, my image was pulled



out in two directions. As I moved backward from the prisms, the two images of me became even more separate. The letters *a b c d e* were drawn on a black board and placed at different distances from the prisms.

The results from these experiments were recorded as below. There remained a lot to integrate on day three.

*The relative positions of
the elements of the
experiment*

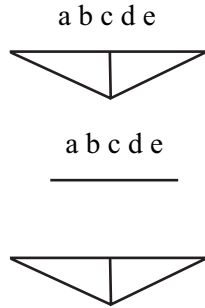

What we saw

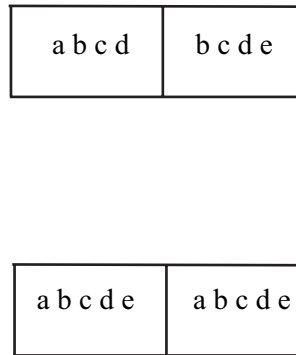

Day Three

We began with the story of Annie Sullivan coming to work with Helen Keller, the little girl struck deaf and blind by scarlet fever when she was eighteen months old. Plunged into a world of darkness and silence at the developmental time when as children we learn to stand and walk, then speak, then think and become self conscious, Helen was surrounded by sympathy as a prevailing soul mood. Her parents, unable to rise above their sympathy, spoiled the little girl and allowed her to do things that were out of control. Her behavior became so wild and uncontrolled that there appeared no alternative than that Helen went to the State Asylum. There was one last chance and a letter was sent to the Perkins Institute for the blind and deaf. This letter reached Annie Sullivan and so the two were brought together for an ego encounter that I believe can be helpful in our understanding of the senses. There is the famous fight over the sausage where Annie refused to allow Helen to pick food off her plate. Then came the ultimatum from Annie that she could only help Helen if she could have her alone in a house for a period of time without the intervention of her parents. God only knows what happened in that house over that time, but we do know that, when the two emerged after some weeks, Helen had experienced an awakening that had been dependent on her meeting with her teacher, Annie Sullivan, an encounter that had not only been one of sympathy but also one of antipathy.

This primary encounter of another ego was seminal in the subsequent awakenings of the other higher senses of thought and word, which are remembered so well in the story of Helen being taught the sign alphabet and even spell words. Although Helen was able to sign many words proficiently, she had no idea that they had any meaning. Then on a fine spring day, April 5, 1887, teacher and pupil went for a walk and stopped at the pump house. While Helen held her hand under the flowing water, Annie signed into it: W A T E R. Suddenly Helen's face lit up and shone with the dawn of understanding, then she dropped

to her knees and pounded on the ground demanding to know the name of this too—E A R T H. For the first time in her life Helen realized that the signs on her hand had meaning. Within minutes she learned another half dozen words. Then she thumped her own head; she wanted to know her own name and then that of her teacher. At last she had realized that she was someone, and with that dawning came the experience of the other.

The stories of Annie Sullivan and Helen Keller are a wonderful instruction of how, amidst the tragedy of an unfolding destiny, a warm human encounter with even one person can make a life-changing difference. The second thing we learn is that the perception of the other ego is one in which we participate. This participation is twofold. It consists of both sympathy and antipathy. Only one does not bring the ego of the other to perception. Helen's parents were not able to perceive the ego of Helen; instead she was regarded as an object of sympathy. Annie on the other hand, was able to perceive Helen's ego and this expressed itself in the antipathy that was part of their encounter.

In this perception of the other ego, something was allowed to live in the world that until then had not been able to. In light of this story, it is interesting that in Lecture 8 in *The Study of Man*, Steiner gives his description of the twelve senses, starting with the ego sense and only then going on briefly to the others. He only goes into detail with the ego sense. What can we learn from this? In perceiving, we are helping to develop the perceived. In that we gain knowledge of something, we perhaps change the development of the beings interacting.

When we look up to the wonder of the starry world, when we contemplate the whole process of the universe with its glories and marvels, then we are led at last to the feeling that all the glory that lies open to our view in the whole universe that surrounds us, only has meaning when it is reflected in the admiring human soul.

– Goethe, quoted by Steiner in Lecture 1 of the series called *The World of the Senses and the World of the Spirit* (Steiner, 1947)

Could it be then that the sense activity is something much more active and creative than the passive, physical process that is often imagined? The integration of the sense activity, which Steiner was already demanding early in the twentieth century, is now part of the training for occupational therapists (personal communication with a former student studying occupational therapy). Below are some of the connections and qualities that were mentioned in regard to this question in the workshop. The twelve senses that Steiner (1966) suggested are listed in three groups with lines connecting them to another sense. The lines connecting the body senses to the Spirit senses are interesting from an educational point of view because they point to transformational potential

(necessity?). The content of the senses can have something to do with oneself, or it can have something to do with telling us about something else.

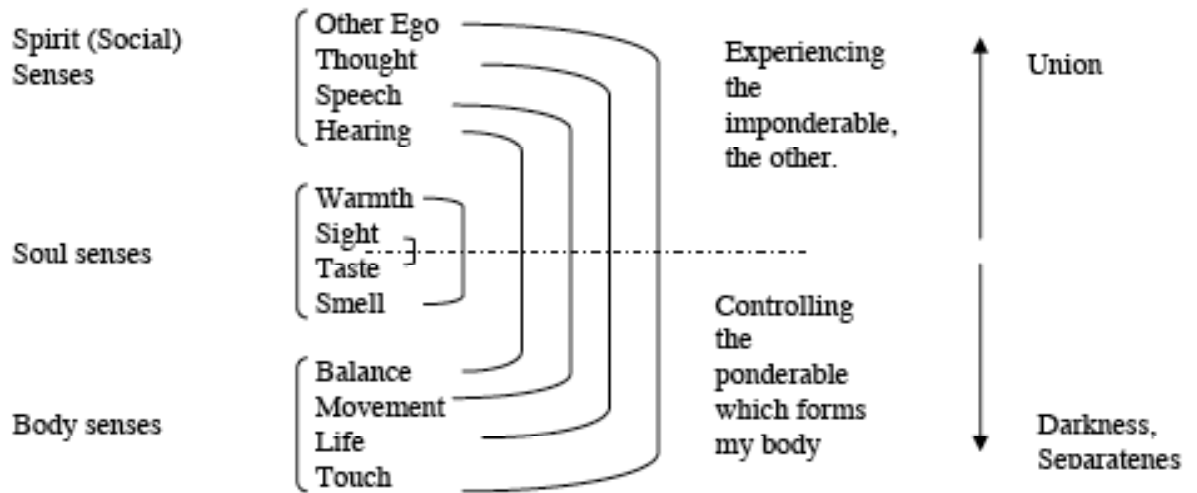

As teachers we need to be aware of these connections and integrate the sensory experiences into our lessons.

Particularly in a subject like physics, it is easy for the lesson to race away in the sense of thought in regard to the mathematical laws of physics. However, as many students get lost in abstraction, it is beneficial, even necessary, to be aware of how the laws of physics are found in the human body, and it is there that they should first be experienced before they are made conscious as thoughts. A friend and researcher at the cutting edge of solar energy research calls this 'body learning.' Using Steiner's expression we could say that learning should be based in the body senses and take place over the whole human being.

In the workshop we began with the experience of seeing the warm and cool colors along the edges of the light and dark surfaces as we looked into a tub of water. This experience was simultaneous with the experience of seeing the image shift in the tub. The image is lifted. But in talking about the experience on the subsequent day, it was clear that our two experiences had been kept separate. There had been no integration of the experiences. It is scary to think about how much of this can go in schools where there are many experiences in a lesson which may remain unintegrated for the student. In Waldorf schools our goal is for the students to integrate their experiences. The teachers do not spoon feed the integration but we give lots of opportunity and support to the students to do this work.

On the second day of the workshop we managed to be clear about what was seen but not about the connections between what was seen. As a workshop facilitator I realized two things: (1) It would have worked better to give the experience of the conditions for the colors on Day 1; this would have made it

fairly easy on Day 2 to come to the connection between the experiences; and (2) Given the situation I had created, the best way forward for Day 2 would have been to come to clarity about what had been seen and about what was still unclear. A whole lot had been learned: what way the image shifted in relation to the geometry of the prism and the surface of the water, that there was something interesting going on between the image shift and the color formation, even how to aim an arrow if you wanted to shoot a fish for dinner. But we had not connected the phenomenon of image shift with that of the colors. So now that we had reached the third day of the workshop, it was time to make the connections (the act of judgment) and also try to develop a living concept of what had been experienced.

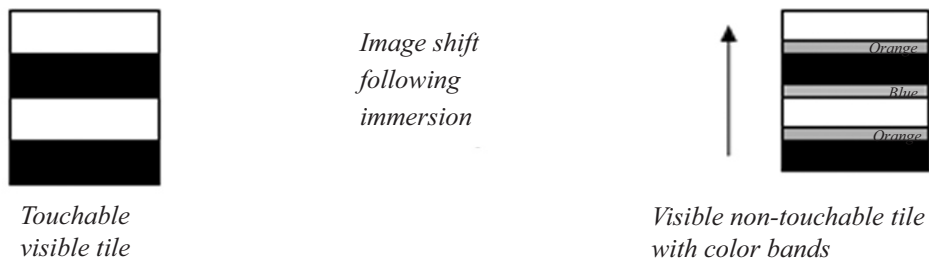

We had discovered from the experiment on Day 2 with the Dettol in water that the turbidity in the water created conditions that were different in relation to light and dark. When the turbidity was in front of the white board or a light window, it darkened the lightness and warm colors appeared. When, however, the turbidity was in front of a black board it had the opposite effect—it lightened the darkness creating cool bluish colors. This is apparently what is happening in the separation of the touchable and visible image, both in the tile-in-water experiment and in the water-prism experiment.

As the image shifts up, where the dark bands move across the light bands, warm colors are formed, and where light bands move across dark bands, bluish colors are formed. This was what Goethe called the archetypal phenomenon: Bluish colors appear when darkness is lightened and reddish colors appear when light is darkened. We are surrounded by this lawfulness everywhere, in the blue of the sky and the warm glow of the transitions from day to night, in the way that a smoke from a fire outside, appears bluish in front of a dark forest but reddish in front of the clear sky.

Here we have the test of a living concept. It does not end with its definition in the lab, allowing us a smug feeling of self-satisfied knowledge possession, but renews our interest to find the underlying laws again and again in the many conditions that appear in the living world. We had also to take the additional step of seeing where the image shift that we had seen in the prism led us. Here too there is a step of integrating different sense experiences. A series of drawings

help in the process of understanding the phenomenon. On the one side there are drawings from the plan view, which show how the elements of the experiment are moved in relation to each other, on the other we have drawings showing what was seen. Again we have an integration of two types of sensory experience, one from the tangible, moving world and the other from the visible world.

From these two results, we can see that the further the object *a b c d e* is placed behind the prisms, the further the shift of the image. So we have a multiplication of images! How can we develop a system that not only multiplies images but also magnifies them? In other words, how do we go from prism shift to magnification? To do this we need to realize that in the image shift, each point was shifted by the same amount towards one pulling edge of a prism. However if we looked through the window of the prism with the wider angle pulling edge, then the shift is increased.

In our example above, the following diagram represents the image shift. Each shift is by the same amount.

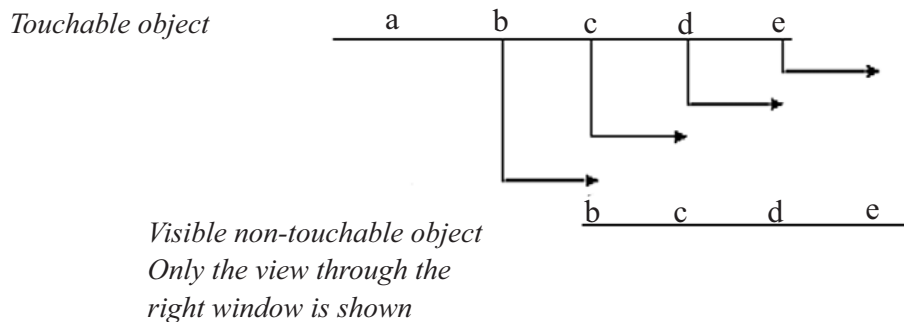

Now what do we need to do so that each element moves proportionally to its distance from the middle point *c*?

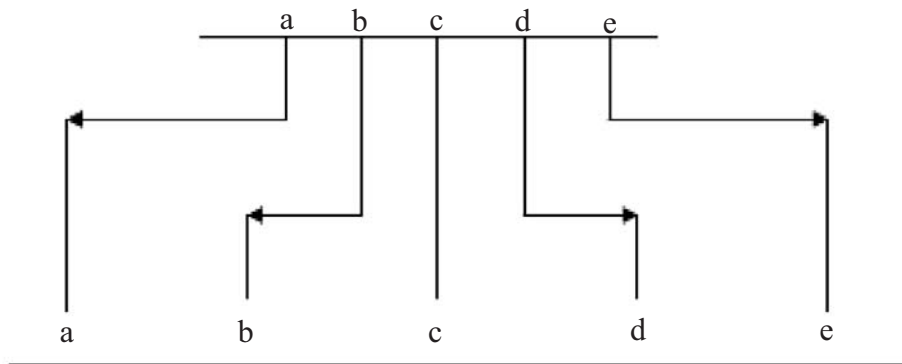

To get this magnified image we would need (1) the central point not to shift as in *c*, (2) *b* and *d* to shift a little, and (3) *a* and *e* to move the most. This would require a series of prisms with no pulling power in the middle (window glass) and an increased pulling power towards the edge.

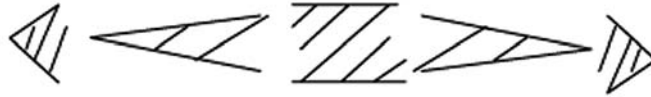

Putting this together would give an arrangement like this:



If this were ground smooth then we would have a cross section like the following figure, which would be the cross section of a convex lens.



Finally we have come to an understanding of the lens, which can lead into a whole world of new phenomena. In the context of our workshop and being the last day, we experienced a series of new phenomena around the theme of the eye. Hopefully our detailed working beforehand had awakened our ability for integrating these phenomena without a great deal of explanation.

Experiment (von Mackensen, 1992): The ‘chaos point’ of a lens. The photographs below show the changes as seen by the workshop participants as the lens is moved away from my eye. The image of the eye is magnified as the lens is moved away from the eye until it reaches the ‘chaos point’ when the lens seemed to be filled with the central point of the eye. This is also the point (i.e., the distance from the lens) when the lens is filled with the sun, as seen from the focal point, which then begins to burn. When the lens is moved beyond this distance, then the image becomes inverted and small—as though the lens goes beyond infinity in the point and returns from the periphery inverted, in a way that is similar to a conic section in the practice of projective geometry.



1. *Lens close to the face*

2. *Lens moved away*

3. *Chaos point*

4. *Past the chaos point to inversion*

Finally a model of the eye was demonstrated using a flask painted in a special way and a convex lens stuck to one side (Maier 1986). The ‘chaos point’ or focal point of the lens is at a point just short of the opposite face of the flask. A hazy image of what is in front of the lens is visible. (It gives an impression of what Annie Sullivan’s limited vision was like during the time she was living in the poor house.)



Model of the eye created with a painted flask

However, when the flask is filled with water, a clear image appears on the wall of the flask opposite the lens. The lens of the eye is the whole eye. The eye too works between center and periphery. It is perhaps the key sense in the sleep process. After all, we close our eyes to sleep. There in the eye we also have the place where we meet ourselves in the other. This has been characterized so well by Ysaye Barnwell in her children’s book *No Mirrors in My Nana’s House*, when she describes how a little girl finds her self worth in the eyes of her Nana.

There are no mirrors in my Nana’s house...
 No mirrors to reflect the cracks in the wall,
 The clothes that don’t fit, the trash in the hallway.
 No mirrors.
 But there is love.
 The beauty in this child’s world is in her Nana’s eyes.
 It’s like the rising of the Sun. . . .

There in the dark pool of the eye called the pupil, separated from the white of the eye by the color of the iris, we find there, where the light of the other gleams forth, a source for our own self-knowledge. There in the dark pool of the night, separated from the light of the day, we find the connection to our peripheral self. This is the secret of the indications given by Steiner to the pioneer teachers at the first Waldorf school. “You must teach the children how to sleep.”

How can we now put this into our day-to-day classroom work with the children? Steiner described a method in his 1921 course for adolescence, Lecture 3 (Steiner, 1965). In the course of the workshop we have tried to practice this method and integrate it with the other indication to working with the night given in his 1919 course to the teachers, Lecture 9 (Steiner 1966). There he characterized the steps of Conclusion (*Schluss*), Judgment (*Urteil*) and Concept (*Begriff*) in this unusual order, specifically beginning with the Conclusion. This conclusion is like a biographic moment—a happening that we witness and is then completed. That is the beginning of the way in the classroom—to go from an event that engages the whole human being, the whole of the lower senses, the middle senses, but without isolating the judgment and conceptualization from the process. Guttenhöfer (2004) has also written about this eloquently.

The Judgment is what is engaged between the biographic impact of the Conclusion and the Concept that is formed. The Judgment is engaged in the feeling life, in comparisons. It must be trained to not fall too quickly, like a bolt from the sky, but in silence and in the night to ripen and then be met in the classroom through questions posed by the teacher out of their contact with the students. The well-prepared questions strike a chord with the students and engage them. It is the teacher's task to find the latent questions that live often unarticulated in the feeling life of the adolescent students. They lead the 'biographic event,' the Conclusion, after a night's sleep over into 'consideration' and the forming of the Concept.

This is the third movement of Guttenhöfer's sonata. What has gone before resolves into a renewed interest in the world, a new connection to the world, By picking up the themes of the biographic event and connecting them to wider and wider circles of phenomena, the Concept that is formed is given shape and meaning but not in the sense of finishing the process of cognition but by leading to new cognition. This is the sense of the 'living concept' as opposed to the 'dead concept.' In summary:

Day One

Experience—as sense-rich as possible, and allowed to happen without commentary or explanation. This is not a time to spread light on everything. This is the Conclusion. It may be an experiment or the telling of a historical event. The whole body should be engaged. This does not mean doing gymnastics.

Characterization—What has been experienced is recalled as though by a witness for the whole of society. In the case of an experiment, the apparatus is cleaned up and put away and the event is recalled. The enthusiasm comes not from explanation but from clarity. The feeling life is touched and the children can be let out for their recess break. The darkness of the unknown is intimated.

Expectancy grows. This forms a healthy beginning to the process of judgment.

Night/Sleep—The events of the day are integrated into the wholeness of the individual biography. Descriptions of the experiences of the lesson may be written up homework if they have not been done during class. Connections are made at an unconscious level; latent questions arise.

Day Two

Questions—prepared by the teacher but also coming from the students. A mood of antipathy prevails in the room. This is not to be confused with unkindness but with demand. Here the teacher is in a position to require something from the students, that they remember what occurred the day before and try and answer the riddles that come from that experience. This can lead to debate to feeling the vulnerability of uncertainty. Disparate experiences are brought to integration and then connected to the real world. A living concept can be formed. A new Experience—a new Conclusion—Characterization.

Night/Sleep—Descriptions of the experiences of the lesson may be written up homework if they have not been done in class. Questions set by the teacher based on the morning's discussion may also be explored

Day Three

Questions . . . and so on. This is the medicine we have as teachers for the young people of today. This is the daily work of the main lesson that can go from day to day, year to year. It forms one part of the day in the Waldorf school, the part that is most active in fulfilling the prerequisite for freedom.

Peter Glasby is a teacher of physical sciences at the Mt. Barker Waldorf School in Australia. He is highly regarded worldwide for his knowledge of phenomenology.

Bibliography

- Barnwell, Y.M. *No Mirrors in My Nana's House*, Florida: Harcourt, Brace and Co., 1998.
- Davidson, M. *Helen Keller's Teacher*, Scholastic Book Services, 1965.
- Davidson, M. *Helen Keller*, Scholastic Book Services, 1969.
- Glasby, P. "Recognizing What Is Human in the Practice of Education," *Journal for Waldorf/Steiner School Teachers* 3.2., 2001.
- Goethe, J.W.v. "Der Versuch als Vermittler von Objekt und Subjekt" in *Naturwissen-schaftliche Schriften. Goethe's Werke, Band 13*, Hamburg: Christian Wegner Verlag, 1960.
- Guttenhöfer, P. "The Division of the Main Lesson and the Role of the Conclusion," *Journal for Waldorf/R.Steiner School Teachers* 6.1, 2004.
- Maier, G. *Optik der Bilder*, Dürnau: Verlag der Kooperative, 1986.
- Steiner, Rudolf. *The World of the Senses and the World of the Spirit*, Six lectures given in Hanover, December 27, 1911–January 1, 1912, London: Rudolf Steiner Publishing Co., 1947.
- _____. *The Study of Man*, 1919 (Now translated as *Foundations of Human Experience*, lectures 8 and 9; London: Rudolf Steiner Press, 1966.
- _____. (1965) *Supplementary Course – the Upper School*, 1921 (also translated as "Education for Adolescents"), Lecture 3. Authorized translation by permission of the Rudolf Steiner Nachlassverwaltung, Switzerland. Translation issued by the College of Teachers, Michael Hall, Forest Row, Sussex.
- _____. *Occult Science*, 1925, Chapter 2, "Sleep and Death," London: Steiner Press, 1969.
- Von Mackensen, M. *Klang, Helligkeit und Wärme*, Kassel, Germany: Bildungswerk, Brabanter Strasse 43, 3500, 1992.